

FNAME: WD3P-4-(3021-3030)

REVDATE: 0520

REVISIONS				
ZONE	REV	DESCRIPTION	DATE	APPROVED
	K	UPDATED TITLE BLOCK	2/4/20	AO
	L	UPDATED XF1	5/20/20	JED

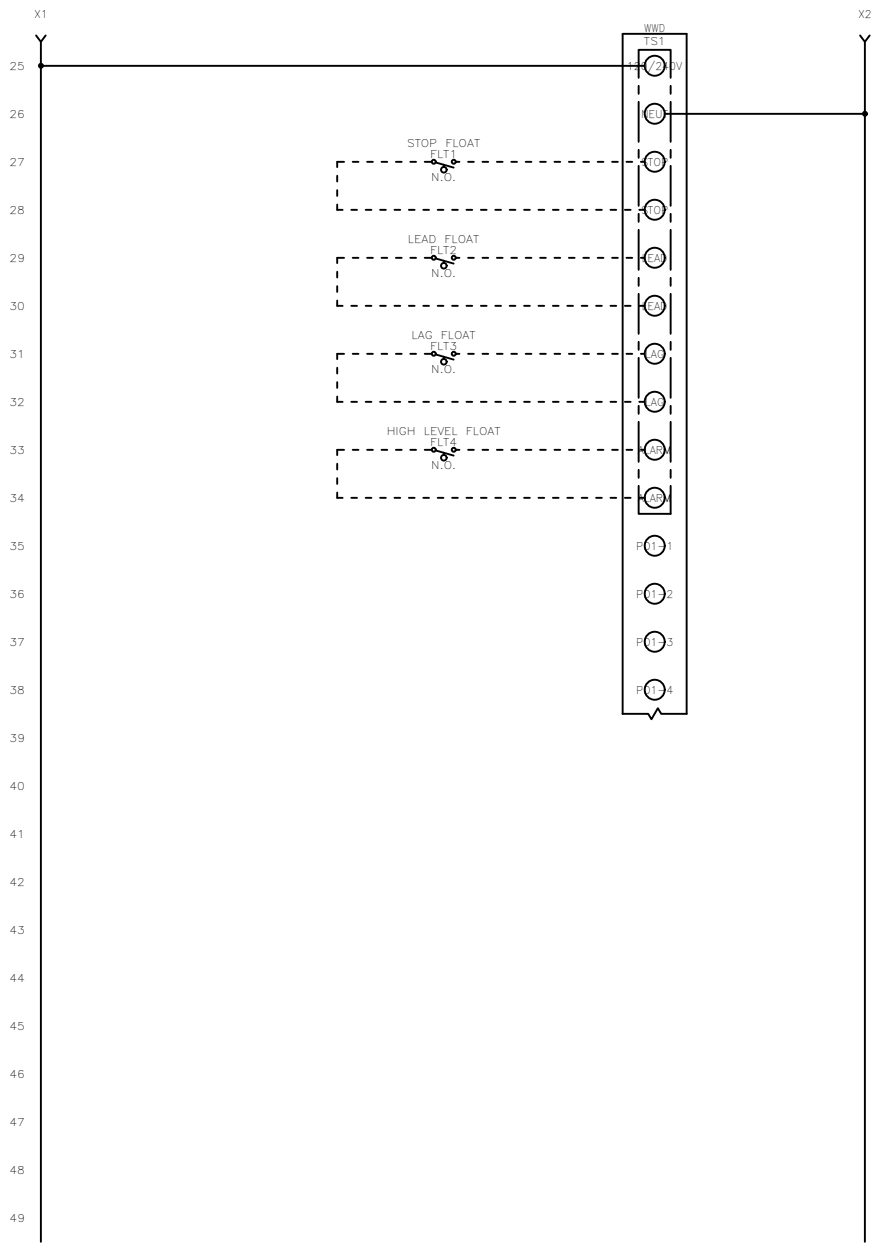
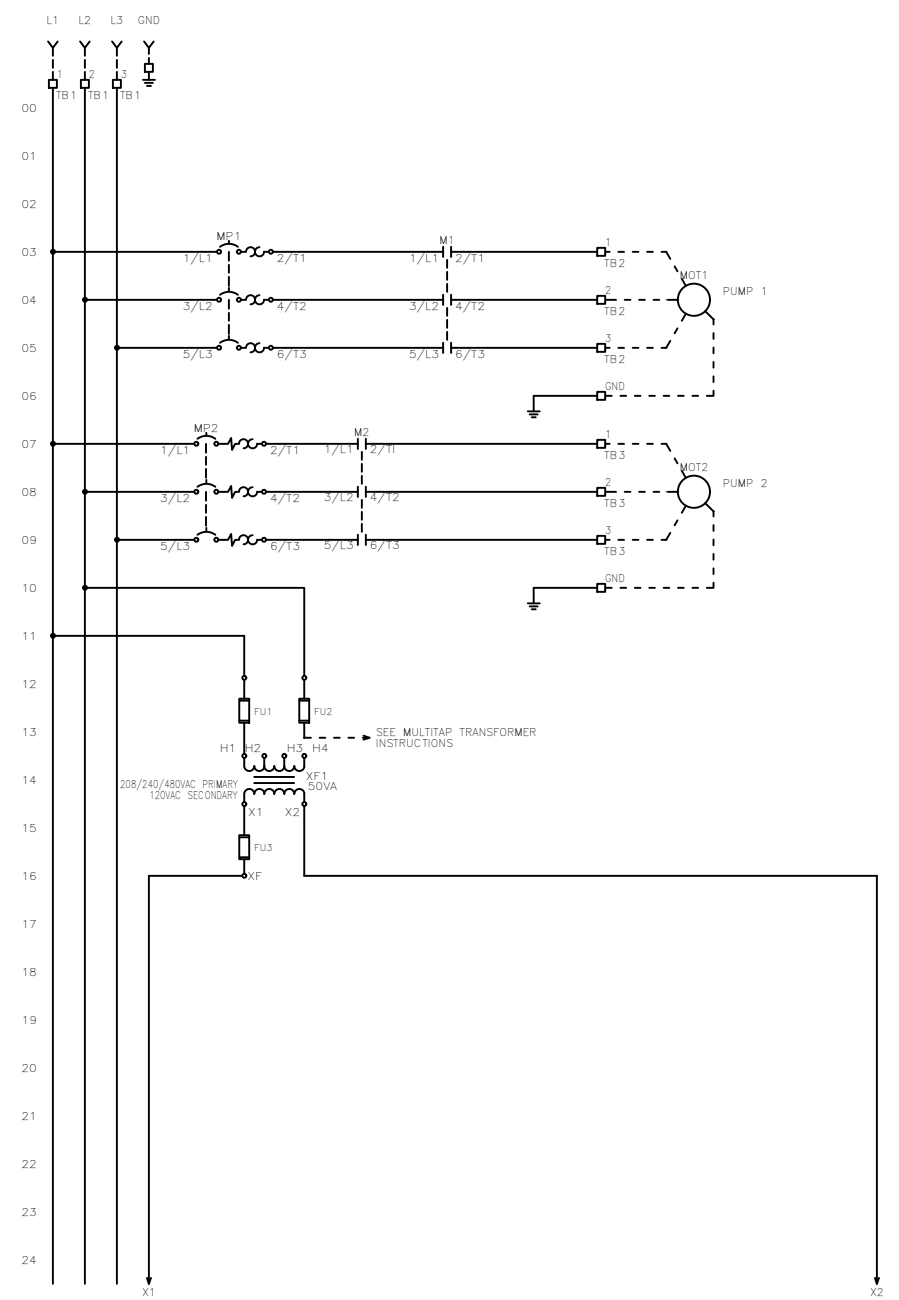

MULTI-TAP TRANSFORMER:

CONNECT FACTORY TAGGED WIRES TO APPROPRIATE TRANSFORMER VOLTAGE TAP. SEE BELOW FOR CONNECTIONS:

FOR 208V OPERATION, CONNECT TO FUSE INPUT HF & TO TRANSFORMER TAP H2.

FOR 240V OPERATION, CONNECT TO FUSE INPUT HF & TO TRANSFORMER TAP H3.

FOR 480V OPERATION, CONNECT TO FUSE INPUT HF & TO TRANSFORMER TAP H4.

----- DASHED LINE INDICATES FIELD WIRING.

USE COPPER CONDUCTORS ONLY.

TEMPERATURE RATING OF CONDUCTORS IS TO BE:
60°C (140°F) FOR UNDER 100A.
75°C (167°F) FOR OVER 100A.

BRANCH CIRCUIT PROTECTION SHALL BE PROVIDED BY THE INSTALLER. MUST BE SIZED ACCORDING TO PUMP/MOTOR MANUFACTURING SPECIFICATIONS.

VERIFY CORRECT OPERATION OF CONTROL PANEL AFTER INSTALLATION IS COMPLETE.

FIELD WIRING TORQUE SPECS.	
TERMINAL BLOCK UT 2,5	5 IN-LB
TERMINAL BLOCK UT 4	7 IN-LB
TERMINAL BLOCK UT 6	15 IN-LB
TERMINAL BLOCK UT 10	15 IN-LB
TERMINAL BLOCK UT 16	25 IN-LB
TERMINAL BLOCK UT 35	30 IN-LB
TS1, TS2, J2 & J3 PCB	5 IN-LB
TRANSFORMER H1F, H2F & H3F	15 IN-LB
TRANSFORMER H1, H2 & H3	10 IN-LB
DS1 VLS3P16-63 R1	16 IN-LB
DS1 VLS3P63-125 R2	45 IN-LB
DS1 LK4JU3CN 100A	36 IN-LB
DS1 LK4MU3N 200A	200 IN-LB

DRAWN BY: KJ DATE: 11/6/14

APPROVED BY: KM DATE: 11/6/14

THIS DRAWING CONTAINS PROPRIETARY INFORMATION AND SHALL NOT BE USED OR DISCLOSED WITHOUT PRIOR WRITTEN AUTHORIZATION.



TITLE: WD3P-4-(3021-3030) CONTROL SCHEMATIC			
SIZE: B	DWG NO.: 1526	PART NO.: WD3P-4-(3021-3030)	REV: L
SCALE: NONE		SHEET: 1 OF 2	

FNAME: WD3P-4-(3021-3030)

REVDATE: 0520

REVISIONS				
ZONE	REV	DESCRIPTION	DATE	APPROVED
	K	UPDATED TITLE BLOCK	2/4/20	AO
	L	UPDATED XF1	5/20/20	JED

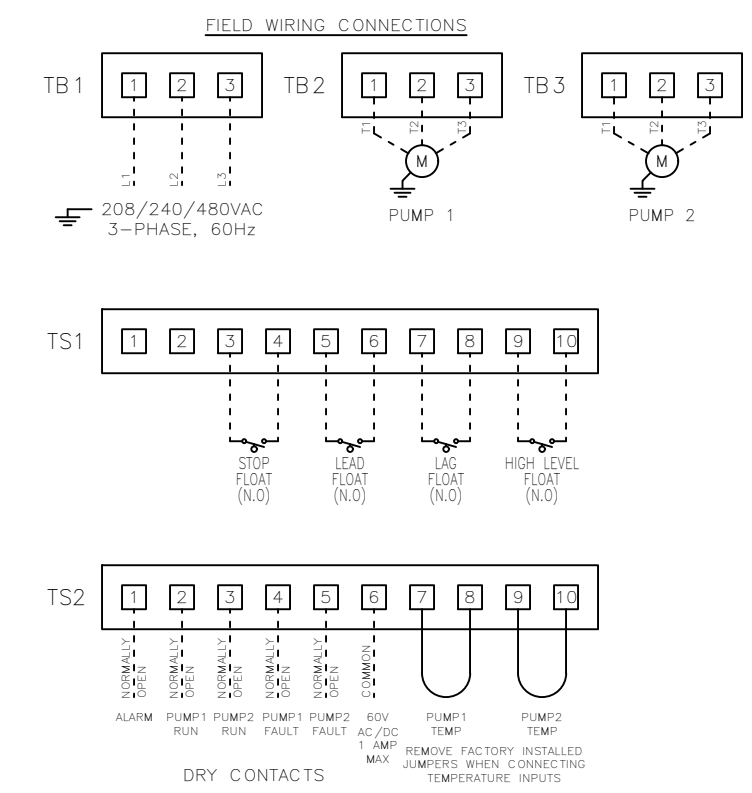
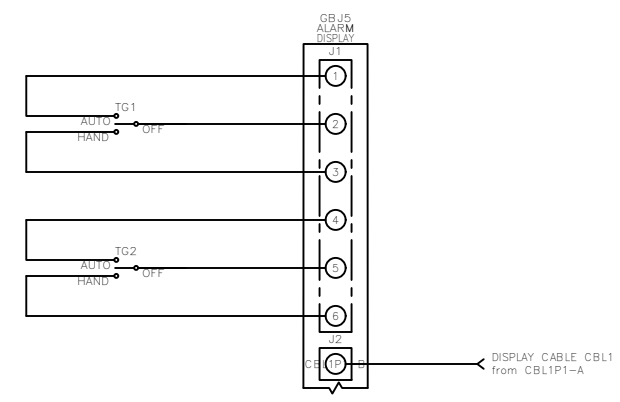
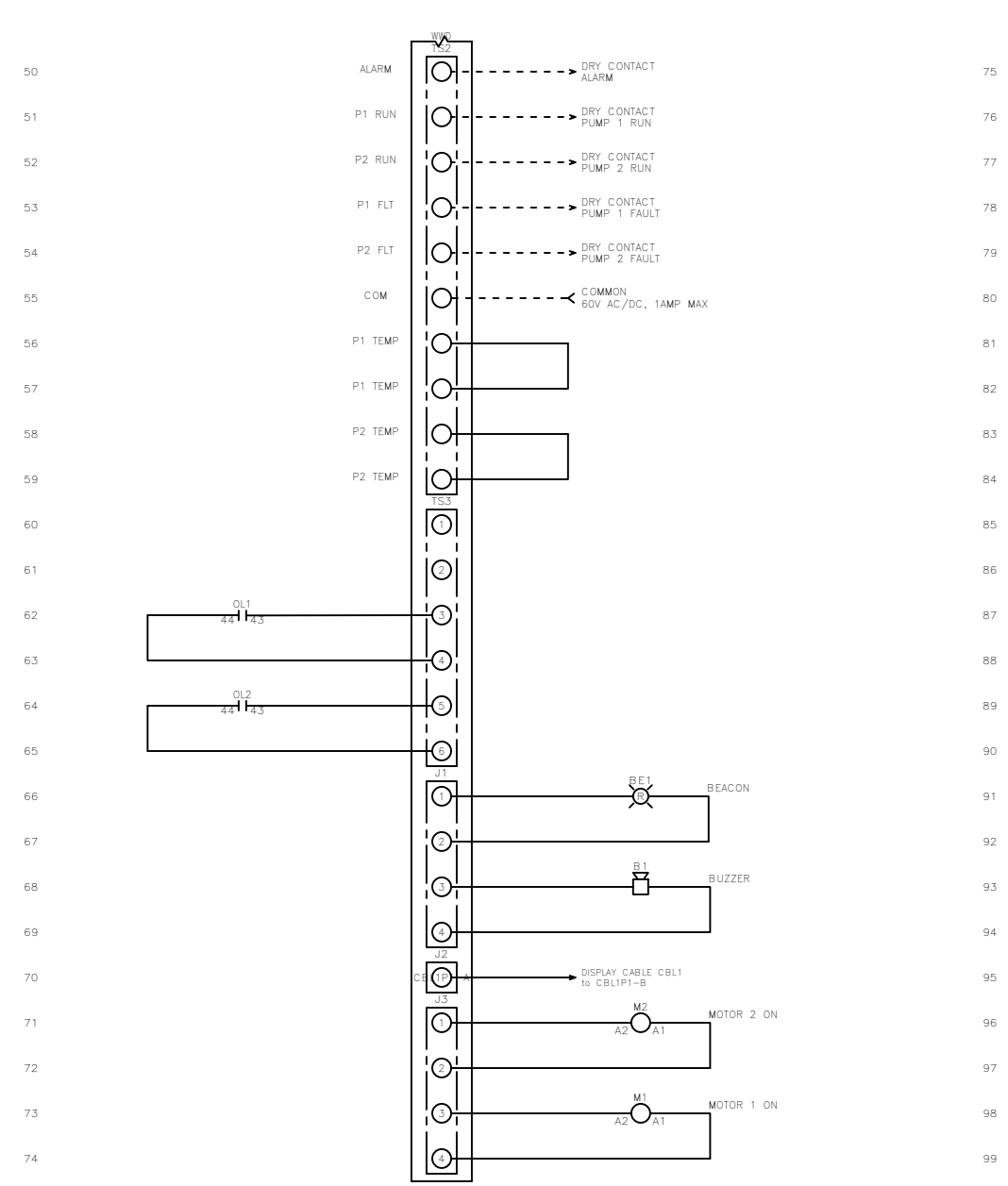

MULTI-TAP TRANSFORMER:

CONNECT FACTORY TAGGED WIRES TO APPROPRIATE TRANSFORMER VOLTAGE TAP. SEE BELOW FOR CONNECTIONS:

FOR 208V OPERATION, CONNECT TO FUSE INPUT HF & TO TRANSFORMER TAP H2.

FOR 240V OPERATION, CONNECT TO FUSE INPUT HF & TO TRANSFORMER TAP H3.

FOR 480V OPERATION, CONNECT TO FUSE INPUT HF & TO TRANSFORMER TAP H4.

----- DASHED LINE INDICATES FIELD WIRING.

USE COPPER CONDUCTORS ONLY.

TEMPERATURE RATING OF CONDUCTORS IS TO BE: 60°C (140°F) FOR UNDER 100A. 75°C (167°F) FOR OVER 100A.

BRANCH CIRCUIT PROTECTION SHALL BE PROVIDED BY THE INSTALLER. MUST BE SIZED ACCORDING TO PUMP/MOTOR MANUFACTURING SPECIFICATIONS.

VERIFY CORRECT OPERATION OF CONTROL PANEL AFTER INSTALLATION IS COMPLETE.

FIELD WIRING TORQUE SPECS.	
TERMINAL BLOCK UT 2,5	5 IN-LB
TERMINAL BLOCK UT 4	7 IN-LB
TERMINAL BLOCK UT 6	15 IN-LB
TERMINAL BLOCK UT 10	15 IN-LB
TERMINAL BLOCK UT 16	25 IN-LB
TERMINAL BLOCK UT 35	30 IN-LB
TS1, TS2, J2 & J3 PCB	5 IN-LB
TRANSFORMER H1F, H2F & H3F	15 IN-LB
TRANSFORMER H1, H2 & H3	10 IN-LB
DS1 VLS3P16-63 R1	16 IN-LB
DS1 VLS3P63-125 R2	45 IN-LB
DS1 LK4JU3CN 100A	36 IN-LB
DS1 LK4MU3N 200A	200 IN-LB

DRAWN BY: KJ DATE: 11/6/14

APPROVED BY: KM DATE: 11/6/14

THIS DRAWING CONTAINS PROPRIETARY INFORMATION AND SHALL NOT BE USED OR DISCLOSED WITHOUT PRIOR WRITTEN AUTHORIZATION.



TITLE: WD3P-4-(3021-3030) CONTROL SCHEMATIC			
SIZE: B	DWG NO.: 1526	PART NO.: WD3P-4-(3021-3030)	REV: L
SCALE: NONE		SHEET: 2 OF 2	